

Single point frame without power drive type CEO



These TOX® Tool Holders can be incorporated into your existing presses and press brakes and offer you a quick, inexpensive solution.

The stroke to be executed and the force depend on the tool used. Please take this into consideration.

Max. press force 45 kN

The stripper force is adjustable, and the tools are easily changed.

The shut height, as well as the required stroke and press force, are dependent on the material thickness and the TOX® Tool Set applied. Please take this into consideration.

Order number round point type	TOX® tools suitable for mounting	TOX® tool order number	
		punch	die
CEO 150.00	Ø 3, 4, 5 mm	10.00.XX	10.01.XX
CEO 150.01	Ø 6, 8 mm	10.00.XX	14.01.XX
CEO 300.00	Ø 3, 4, 5 mm	10.00.XX	10.01.XX
CEO 300.01	Ø 6, 8 mm	10.00.XX	14.01.XX

1.Stripper

- CEA 10.19 up to 5 mm TOX® point Ø 4000 N max. stripping force
- CEA 10.22 from 6 mm TOX® point Ø 8000 N max. stripping force

2. stripping force adjustment

3. punch stripper on cup springs

4. pull-back spring

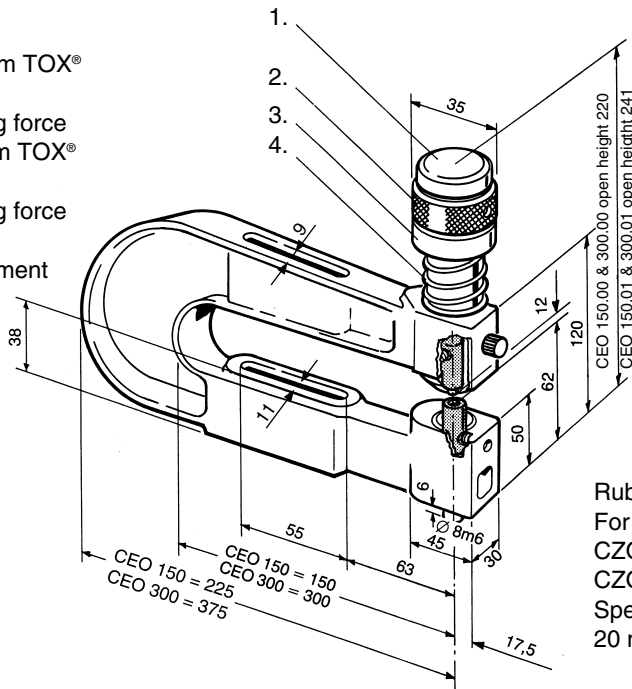

Rubber die side stripper.
For spare strippers please order:
CZO 10 for 3-5 mm point Ø
CZO 14 for 6-8 mm point Ø
Special die length for CEO frames
20 mm.

Scissor gauge



CMT 38

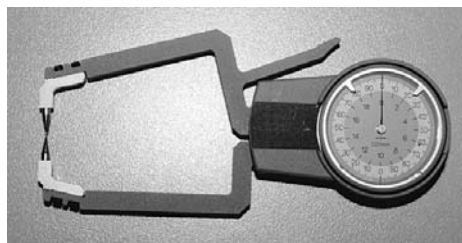

CMT 85/CMT 173

These calipers can be used to check the quality control dimension "X".

control dimension "X"

punch side
die side



Type	CMT 38	CMT 85	CMT 173
Measuring range	0-10 mm	0-20 mm	0-50 mm
Scale graduation	0,1 mm	0,02 mm	0,05 mm
Throat depth	38 mm	85 mm	173 mm