

# TOX® Powerpackage type EK with Total Stroke Limiter and Adjustable End of Stroke Cushion

Type ZSD, Cutting impact dampening

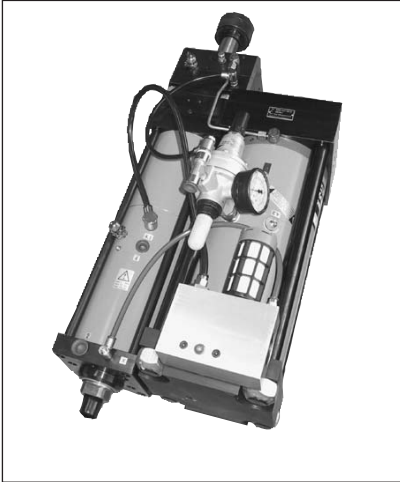

Ideal for dampening in punching applications and for smooth operation of machines during approach or power strokes. Available for all TOX®-Powerpackages type EK with total stroke limiter.

#### Advantages:

- Hydraulic dampening of end of stroke
- Cushioning infinitely adjustable
- Total stroke infinitely adjustable
- Can be mounted in any orientation
- Protects tooling and machine
- Reduces noise levels
- Maintenance-free

#### Function:

The adjusting nut (total stroke limiter) **1** contacts the dampening piston **2** during approach or power stroke depending on the adjustment position. The dampening piston **2** compresses hydraulic oil through the throttling needle **3**. The dampening effect can be adjusted with the throttling needle **3**. During the return stroke, the dampening piston **2** is pushed back to its original position by the pneumatic piston **4** and through the integrated bypass valves. The maximum dampening stroke is approximately 7 mm.

#### Controls:

Pneumatic controls same as for the TOX®-Powerpackage.

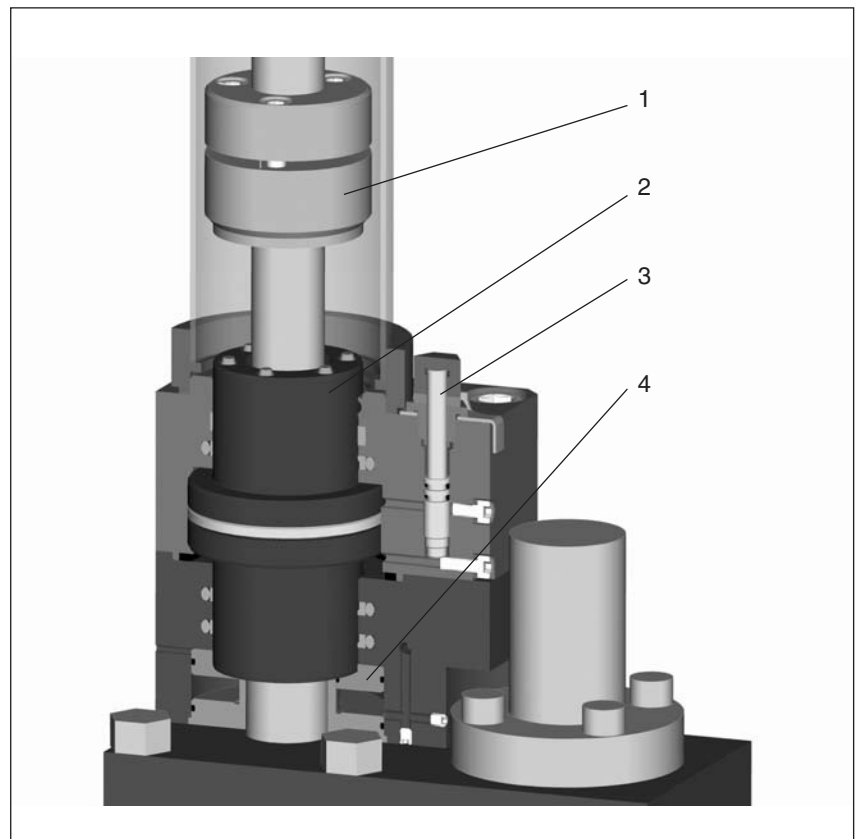

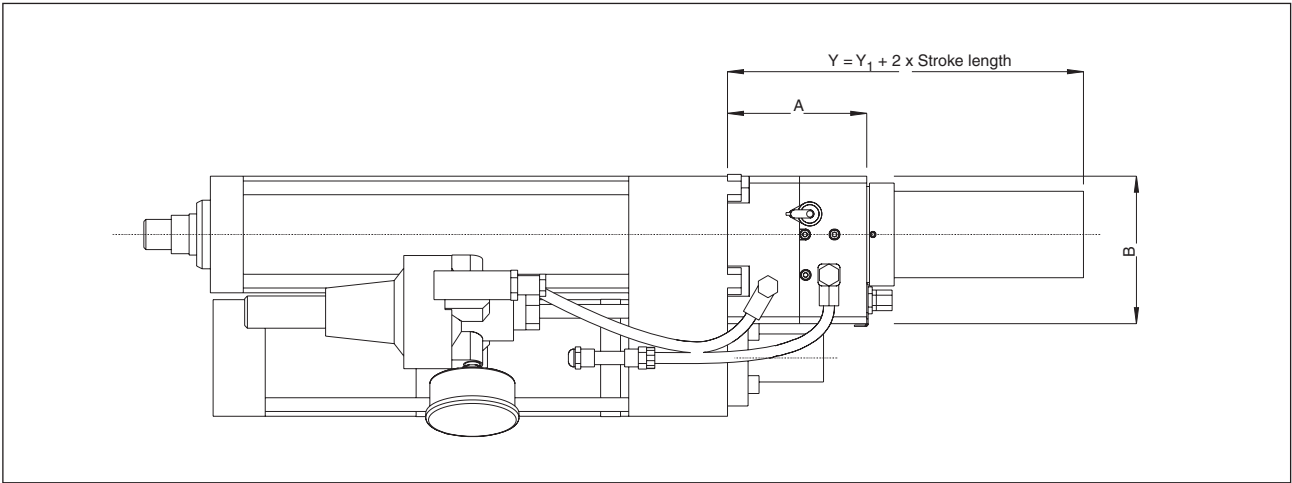

Type	A	B	Y <sub>1</sub>	Y	For TOX®-Powerpackage type EK with total stroke limiter
ZSD 02	4.17	3.94	2.13	Y = Y <sub>1</sub> + 2 x stroke length	for EK 02... for stroke 100 mm
ZSD 04	4.00	4.23	2.36		for EK 04... for stroke 100 mm
ZSD 08	4.00	5.71	2.64		for EK 08... for stroke 100 mm
ZSD 15	4.74	7.15	3.27		for EK 15... for stroke 100 mm
ZSD 30	4.74	9.88	3.94		for EK 30... for stroke 100 mm
ZSD 50	4.82	11.61	4.13		for EK 50... for stroke 100 mm
ZSD 75/100	5.12	15.55	5.12		for EK 75.../EK100... for stroke 100 mm

Dimensions for all TOX®-Powerpackages type EK with total stroke limiter on request.  
For stroke length, see data sheet 10.06 TOX®-Powerpackage with air spring.

**Mounting:**

Can be mounted in any orientation.  
The hydraulic cushion works in any position.  
The adjustable hydraulic cushion is completely installed on the cylinder.  
No plumbing is required by customer.

**TOX®-Powerpackages with ZSD:**

All TOX®-Powerpackages type EK with total stroke limiter, except for EK 02 in version 51 or 81, can be supplied with the ZSD option.

Please refer to data sheet 10.06 for the complete TOX®-Powerpackage program with air spring EK.

**Order-No.:**

EK04.51.200.20 - ZSD

