

C-Frame-Benchtop Presses

Series MC



Our modular design simplifies the selection of a TOX®-Press that fits your individual needs.

Controls: per your requirements, see page 20.

NOTE: press shown may include optional equipment.

Design:

Robust cast construction with adjustable working height.

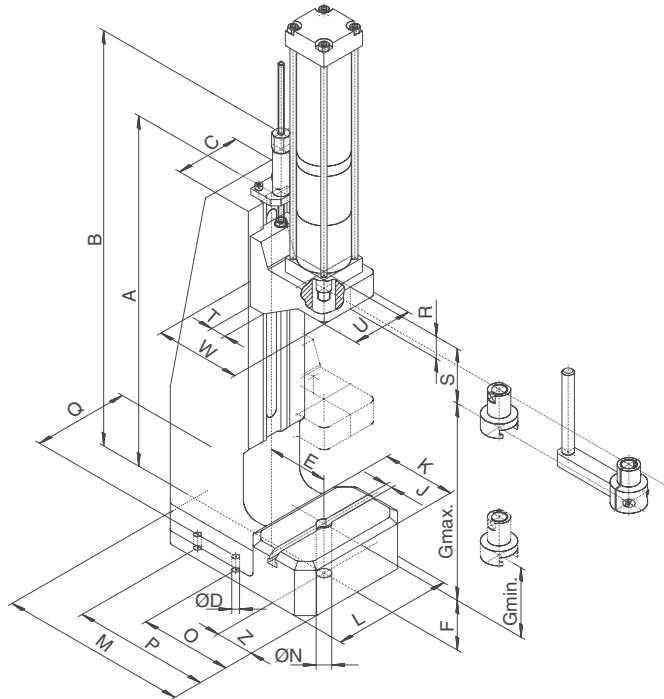

Ordering example for a TOX®-Press MC

Consisting of:

- MC**..... TOX®-Pressframe
- S/K/HZ** TOX®-Powerpackage
- STE**..... Safety controls

Options:

- UUM**..... Machine base
- W** Tool fixture
- ZKF**..... Coupling flange
- V** Antirotating fixture
- ZDO**..... Pressure switch

TOX®-Presses MC

Dimensions in inches.

Order number	Capacity (t)	TOX®-Powerpackage	A	B	C	D	E	F	G _{max}	G _{min}	T-Slot	J	K	L	M	Ø	N	O	P	Q	R	S	T	U	W	Z
MC 2	2	S 2	21.70	27.00	4.02	.40	3.40	3.07	16.1	7.6	.39	4.50	7.40	11.60	.80	5.7	-	5.9	1.30	2.80	1.02	3.75	5.30	2.36		
MC 4.8	4.8	S 4	21.50	23.25	6.30	.55	5.10	4.10	15.1	8.8	.55	7.50	9.85	15.20	-	9.3	-	7.9	1.70	3.50	0.98	4.75	7.50	3.75		
		S 8																							4.50	
MC 9	9	S 8	26.00	27.75	8.25	.55	5.90	6.30	16.1	11.8	.55	8.70	12.20	19.70	-	11.4	-	10.2	2.25	4.50	1.30	8.10	8.70	14.15		
		S15																							4.50	
MC 9T	9	S 8	32.00	33.75	8.25	.55	5.90	7.50	22.0	10.8	.55	8.70	12.20	21.70	-	11.4	-	10.2	2.40	4.50	1.60	8.10	8.70	4.15		
		S15																							4.50	
MC 15	15	S15	25.6	27.6	8.07	.51	5.90	7.28	12.48	8.15	.55	8.66	12.2	19.68	-	7.87	15.75	15.7	2.87	4.57	1.97	7.87	9.84	4.33		
		S30																							5.39	

Press drive:

These presses can incorporate any of our S/K-TOX®-Powerpackages or TOX®-Hydraulic cylinders type HZ. Total strokes up to 400 mm. Powerstrokes up to 200 mm.

For accessories, please refer to individual data sheets.
G = dimension from bolster to cylinder mounting surface.