

TOX®-Joining-Systems

TOX®-Round Joint

TOX®-SKB

TOX®-Flat Joint

TOX®-MICROpoint

TOX®-TWINpoint

TOX®-Vario Joint

TOX®-ClinchRivet

NEW
NEW

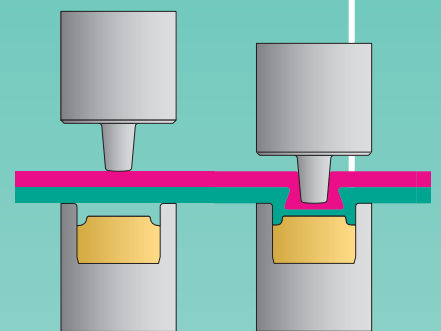

The TOX®-Joining-Systems

The best answer to every challenge.

Why a new technique?

Because all previous methods have involved economic and technical problems. Take welding, for example. A complex, expensive process which can only be applied to precoated sheet metal or aluminium with great difficulty. Surface coatings are damaged or sheet metals are not joined properly. And there is still no reliable automatic process control for all these imponderable factors.

The TOX®-Joining technique puts an end to these problems. It joins different materials by means of a deep drawing-pressing process. And it does so without damage to the surface, purely by displacing and forming.

Practice has already shown the benefits of TOX®, both technically and economically.



TOX® advantages for a good connection



See for yourself:

- + TOX®-Round Joint: 30 to 60% cost savings as compared to spot welding.
- + The TOX®-Joint achieves up to 70% of the static strength of a spot weld.
- + The dynamic strength of TOX®-Joint is higher than in spot welding.
- + The process can be automatically monitored and documented.
- + Simple, non-destructive quality control is possible.
- + The materials are strain hardened at the connecting joint and are therefore stronger compared to spot welding, which has significant stresses around the weld nugget, the TOX®-Joint does not exhibit any metallurgical residual effects.
- + Optimal corrosion resistance with galvanized and prepainted materials, since the protective layer flows with the material.
- + Perfect joints are produced even with narrow flanges and small mounting spaces.
- + Outstanding conductivity for electric components.
- + Cold forming process is ideal for hybrid connections (gluing and clinching).
- + The TOX®-Round Joint can carry shear and pull stress loads, independent of the load orientation.

Convincing features:

- + The TOX®-MICROpoint is especially applicable for very thin metal sheets.
- + The TOX®-TWINpoint: a non-rotating TOX®-Point for small flange widths.
- + TOX®-ClinchRivet
Comparable strength to self-piercing rivets but without cutting the sheet metal layers.

For each operation a suitable solution:

- Point diameter from 1,5 to 26 mm
- Individual sheet thicknesses from 0,1 to 11 mm
- 2 – 4 sheet metal layers
- Composite layers (steel/glue/aluminium)
- Extensive know-how
- World-wide service

How may we help you?

With our TOX® test report we guarantee our technology.



Dr. Rudolf Eberle innovation prize for exemplary achievement.

TOX®-Technology

Clinching facts

The strength behind the TOX®-Joint

In the TOX®-Round Joint process, the material strain hardening in the neck area and the lacking of any notch effects produce the high retaining forces. This is the direct result of the fixed, rigid die. For this reason, even the TOX®-SKB die has fixed segments.

The TOX®-ClinchRivet process combines the advantages of the Round Joint with those of a riveting process.

This is how a TOX®-Joint is formed

- Penetration
- Interlock formation of punch side sheet metal
- Completed TOX®-Joint

TOX®-Round Joint

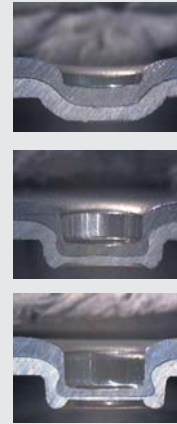

TOX®-ClinchRivet



Durability of TOX®

Static strength up to 70% of a spot weld, with positive strain hardening, without damage to the surface coating, and typically more economical. Isn't all this worth looking at?

Fatigue strength under the most adverse conditions.

Corrosion tests have shown that because the surface coating is not damaged during the round joint process, the anti-corrosive properties of the joined sheet metals, e.g., aluminized or galvanized, are maintained. The TOX®-Joining-System does not cut the surface of the materials to be joined, as the coating flows with the material and remains intact.

Test series standard tool set (without tool change)

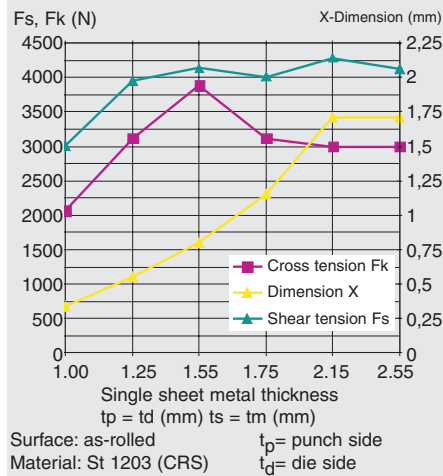

Corrosion test

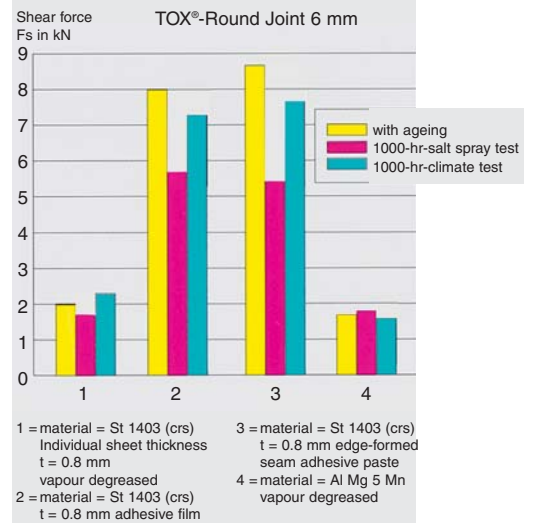

The dynamic strength is higher than in spot welding.

Advantageous dynamic strength without notch effect in the joint - this means: the life of the TOX®-Round Joint lasts much longer than that of a weld point.

On the right:

The TOX®-Joint in customer test

Results of endurance tests for samples with TOX®-Round Joints and spot welds.

The joints were exposed to an initial load of 1 kN and a frequency of approximately 35 Hz. The fatigue life of the joint was measured until failure.

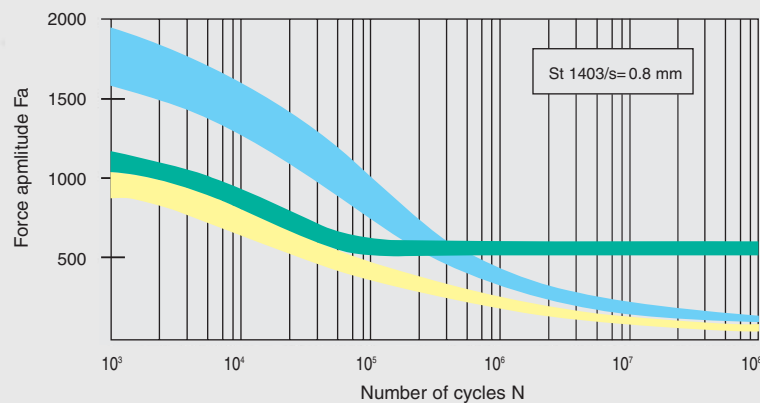

Joined samples, vapour degreased

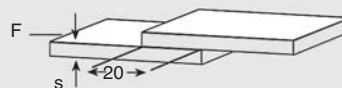

$F_D, 100\%$	F_D = fatigue strength
280 N	Spot welding
250 N	Clinching, star shape
560 N	TOX®-Round Joint

Source: EFB (German Research Group) research report No. 37

TOX®-Technology

The advantage for you and the environment:
cost effective and efficient

TOX®-Joining: the simple process cuts your manufacturing costs.

The system efficiency and the service life of the tools are closely interdependent.

(1) shows a cost comparison for the single joint technique between spot welding and TOX®-Joining for a mild steel application. The TOX®-Joining-System can be used in multipoint applications, which can increase considerably the cost difference between TOX®-Joining and spot welding.

(2) shows the normal service life of TOX® tools. The given values and guidelines depend on the particular application.

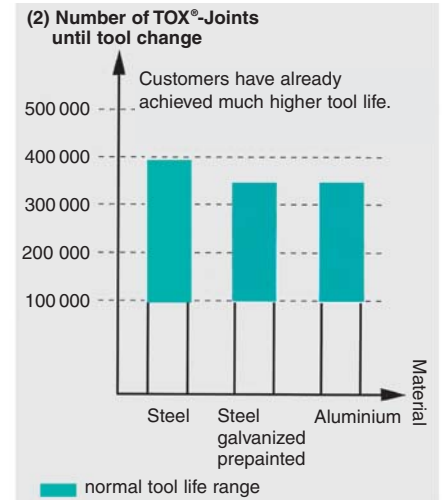
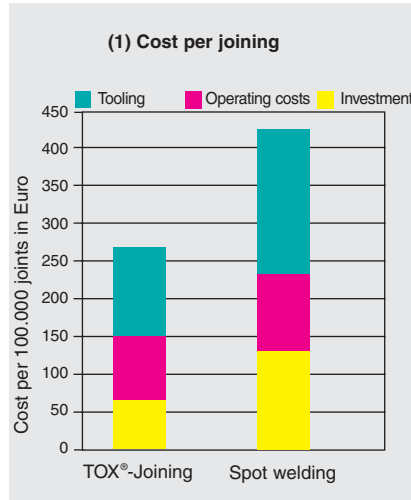

TOX®-Joining of Stainless Steel

Stainless steel presents special requirements for forming processes. The required higher forming forces result in higher surface stresses on the joining tools. The TOX®-Joining Technology can be used safely and efficiently even for stainless steel applications. Continuous tool development and experience with many applications have resulted in high tool life.

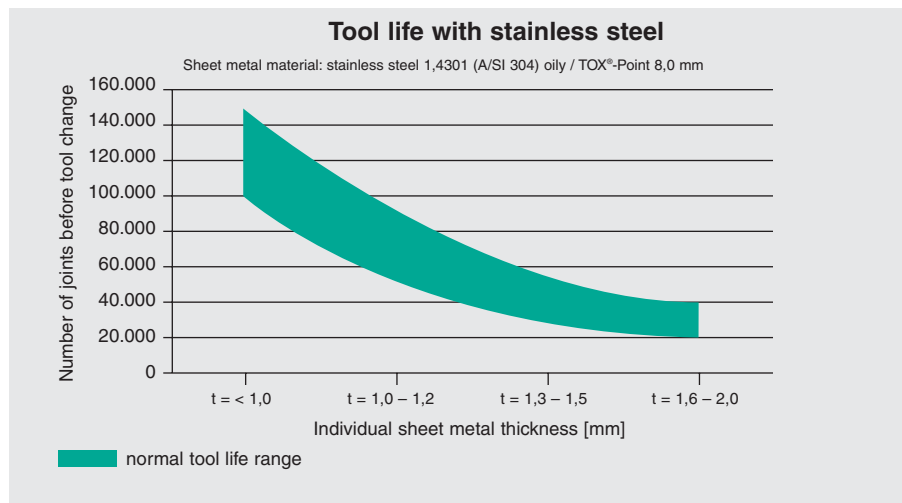

TOX®-ClinchRivet

The TOX®-ClinchRivet is a logical further development of the TOX®-Round Joint with greater resistance for crash applications. By filling the joint with the rivet, the TOX®-ClinchRivet process increases the joint strength considerably, especially the shear strength. Higher strength can be achieved when compared to pierce rivets, especially with thin sheet metals. It is important to mention that with TOX®-ClinchRiveting, the upper sheet metal layer will not be cut: no risk of corrosion.

See data sheet 80.04 for additional information.

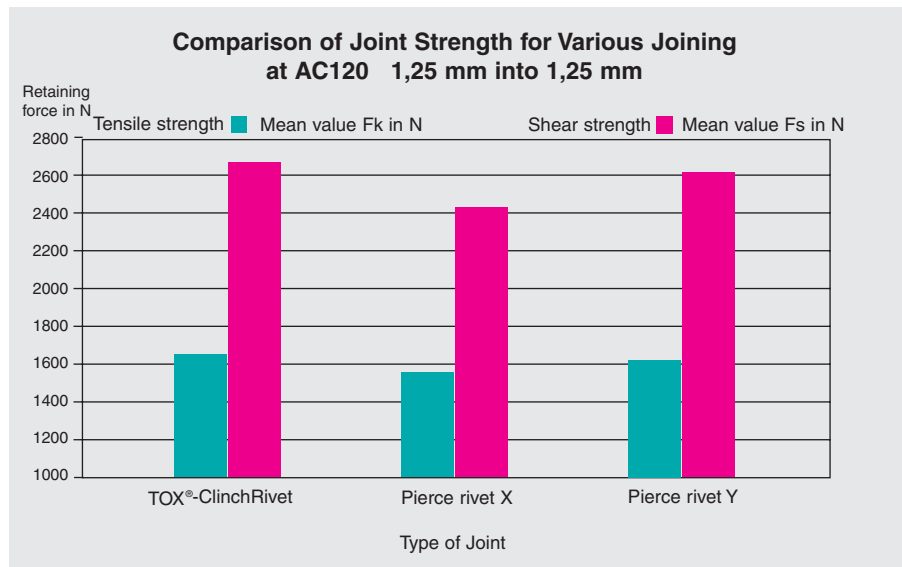

The TOX®-Joining-Systems: Simplicity is our strength.

TOX®-Round Joint

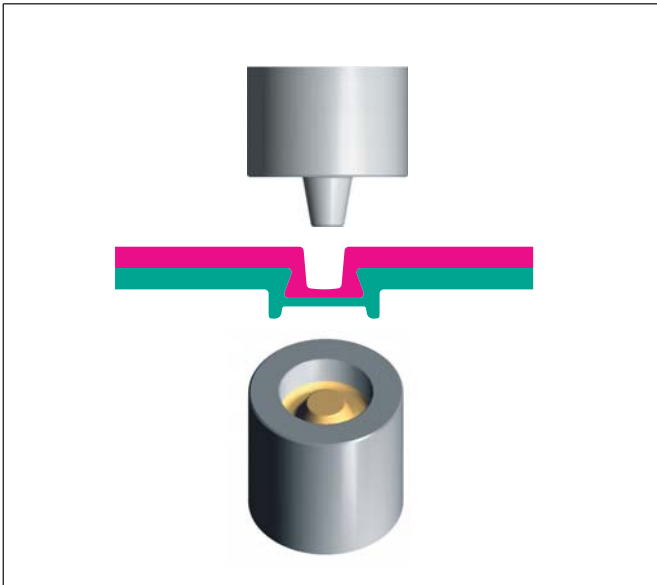

The patented **TOX®-Round Joint** is the core of our technology. A simple round punch presses the materials to be joined into the die cavity. As the force continues to increase, the punch side material is forced to spread outwards within the die side material. The result: an aesthetically pleasing round button, which joins clearly without any burrs or sharp edges on which corrosion could set in. Even with aluminized or galvanized sheet metals, the anti-corrosive properties remain intact as the protective layer flows with the material. Find additional information in the data sheet 80.100.

TOX®-TWINpoint

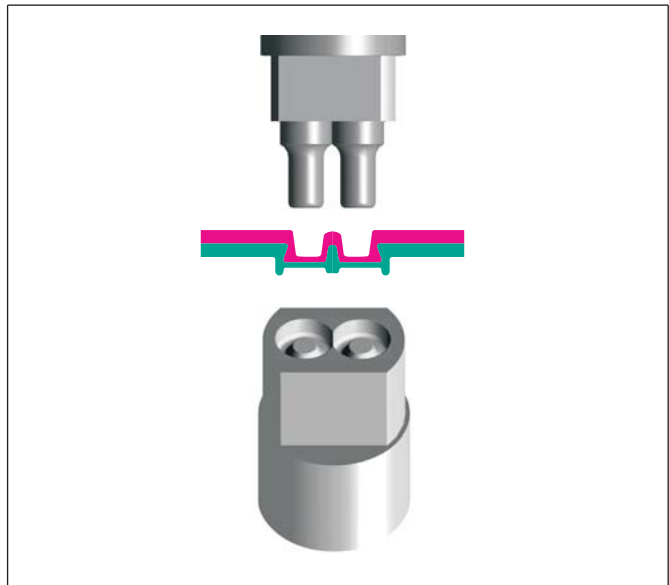

This **TOX® double point** with almost double the strength of a single point prevents rotation of the two layers against each other. The **TOX®TWINpoint** guarantees optimum electrical conductivity over the smallest area. This point also features a solid die with the same simple process and the advantages of the **TOX®-Round Joint**.

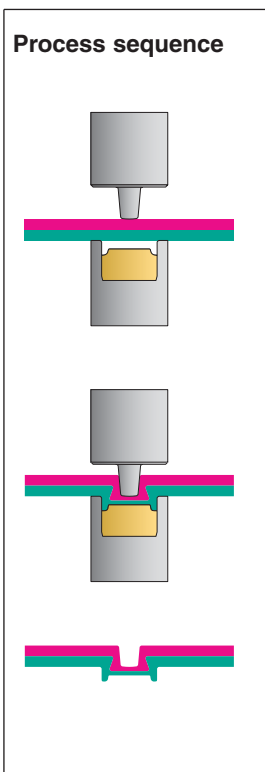

Process sequence

The TOX®-Round Joint: Smart Joining Technology with no added fasteners.

Strength:

The materials are plastically deformed in the joining area, therefore, increasing the strength. There are no stress concentration factors. The advantages of the **TOX®-Joining-System** can also be appreciated in regards to the **environment** - particularly in comparison to welding. Just think of welding aluminium, galvanized or prepainted sheet metal!

Cutting costs with TOX®

Besides the directly measurable cost advantages, considerable savings can also be made with a much simpler production sequence. For example, it is often possible to punch, bend and join in one progressive die. This saves an entire working cycle as well as transportation to the joining station - or welding shop. Which is a great advantage in terms of logistics.

TOX®-MICROpoint

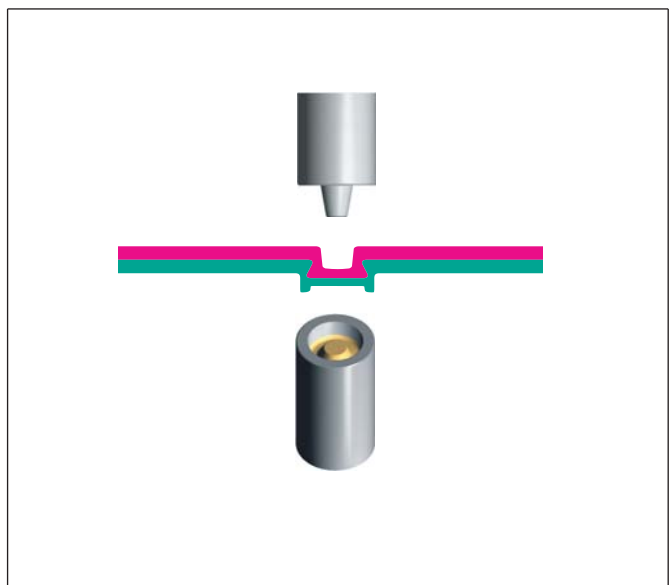

The miniature **TOX®-Round Joint** with point diameters of 1.5 to 2 mm is the answer to the miniaturization of components. It is ideal for sheet metal thicknesses from 0.1 – 0.5 mm and narrow flanges. The electrical conductivity between the joined layers is comparable to other connections.

TOX®-SKB

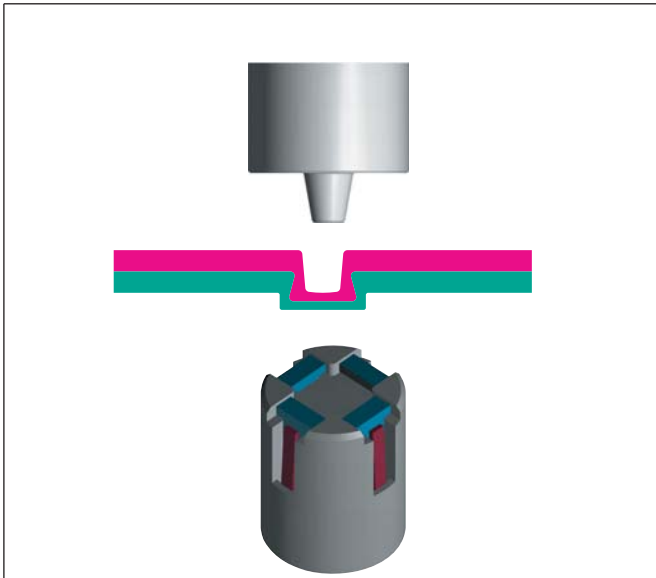

A special clinch-die has **solid and flexible** segments. The materials and the punch are centered by the fixed segments, thereby guaranteeing that the joint formation is perfectly concentric. The mobile elements between the solid segments allow an interlocking of the material in the joint.

TOX®-Flat Joint / TOX®-SKB flat

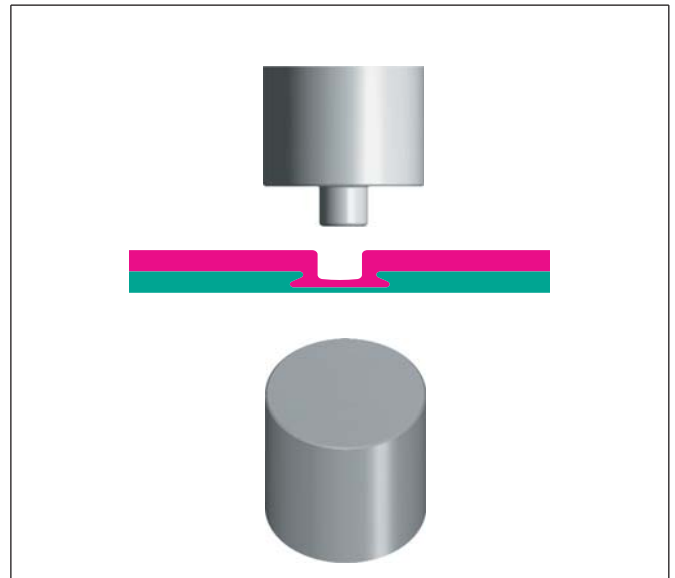

In some instances, the button formed by the TOX®-Point may be undesirable. That's why we developed the **TOX®-Flat Joint**.

Process sequence

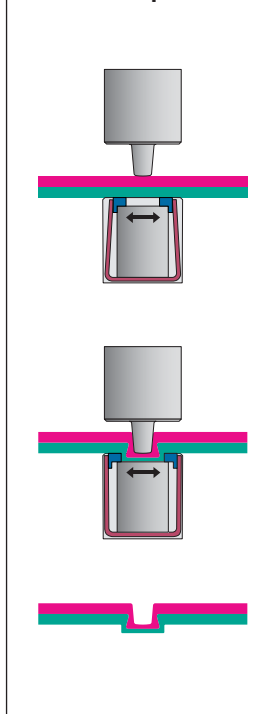

The advantages are seen in a **more flat protrusion of the joint** and a **higher flexibility** when sheet metals of different thickness have to be joined with one tool set.

The special arrangement of the springs allows extremely slender tools and thus better accessibility and **minimal interference** compared with conventional die construction without solid part.

The SKB die shows its strength specially when **glue** is used between the sheet metal layers. Furthermore, it has been successfully implemented for the TOX®-ClinchRivet (see page 8).

Process sequence

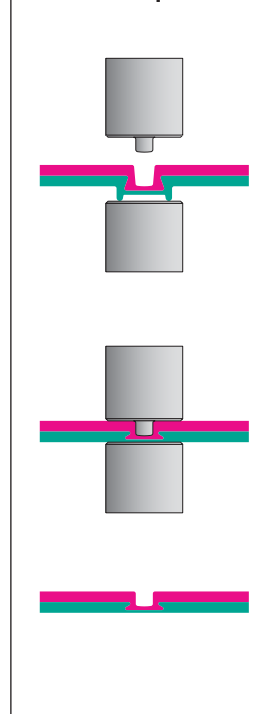

Forming the TOX®-Flat Joint:

- the first step is to produce the standard TOX®-Round Joint or TOX®-SKB Joint
- The resulting button is flattened ($\pm 0,1$ mm) in a secondary operation.

The high shear and pull strengths of the TOX®-Point are left virtually intact.

Specialities of the procedure

TOX®-ClinchRivet

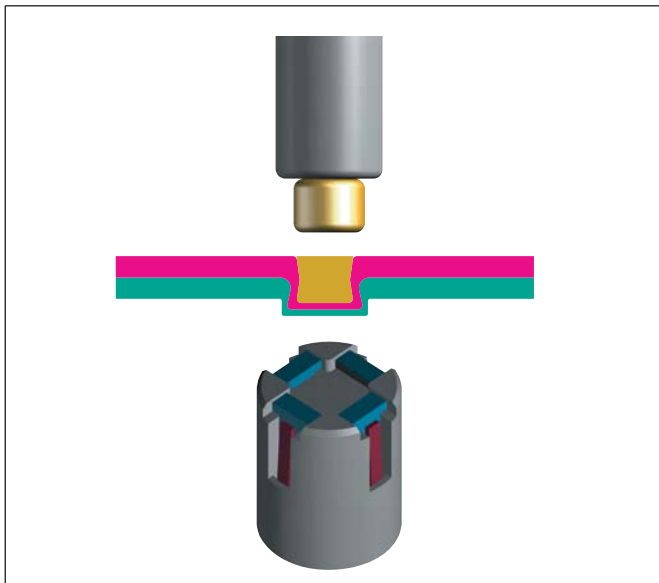

In the case of the patented **TOX®-ClinchRivet**, the actual rivet joining is made from a simple cylinder rivet in a joining process using drawing/pressing methods. Similar to the TOX®-Round Joint, the material to be joined is not cut but led through the die form thus producing a very resistant joint - also in the case of thin materials.

Multijoint applications increase cost advantages. Find additional information in the corresponding data sheet.

TOX®-Vario Joint I TOX®-Vario Joint II

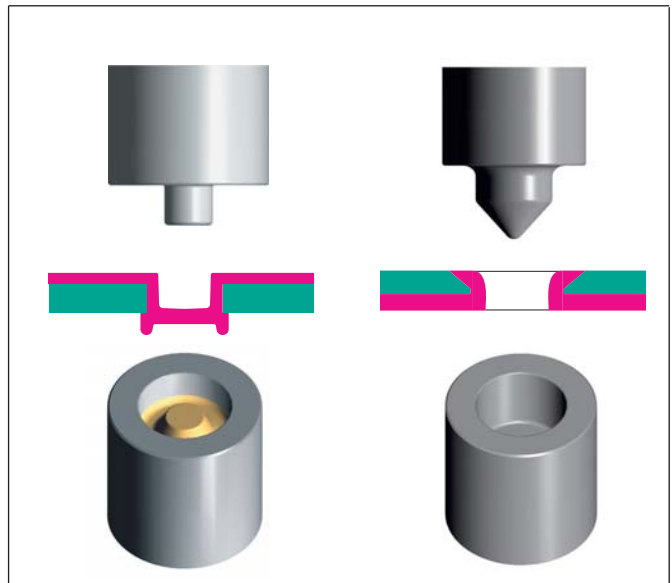

The **TOX®-Point** for difficult cases: joining of sheet metal with large differences in thickness, joining of high strength or non ductile materials with ductile materials or joining of non metallic materials.

Characteristics: one layer is pre-punched, the ductile material is then pushed through the hole. The connection has radial and axial strength. Multiple joints can be applied in a single press stroke. This process requires precise alignment of the parts.

Process sequence

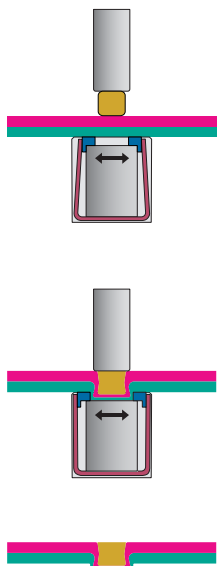

The special advantage of the **TOX®-ClinchRivet** is the simple, symmetrical and inexpensive rivet. This results in the troublefree feed and compression. The materials to be joined gain an additional retaining component. A clean and highly reproducible joint is created.

All technological characteristics and quality criteria of the TOX®-Round Joint also apply to the TOX®-ClinchRivet.

Process sequence

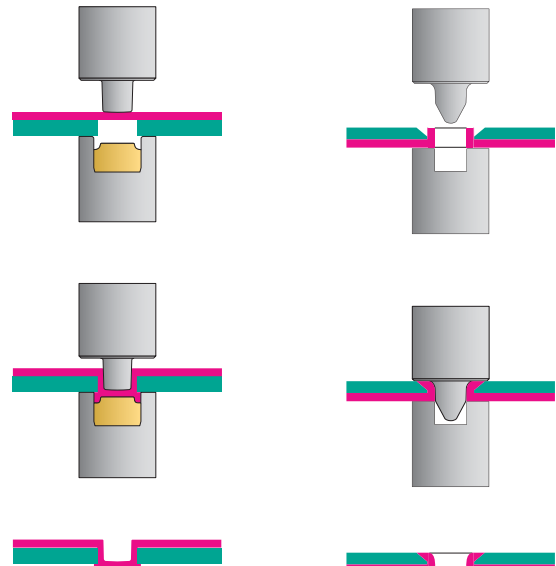

TOX® Standards:

The modular program - flexible and field-proven

TOX® Tools



TOX® flat plate die offers unbeatable access in hard to reach corners.



TOX® Tool Holder with integrated stripper



TOX®-ClinchRivet standardized swage heads including feed and fill level control for installation in single and multijoint applications. Appropriate for robots.

TOX® Die Sets

the most economical way to use TOX®. Multiple points can be produced in one operation.



TOX®-Handheld tongs the suspension offers an optimum handling.

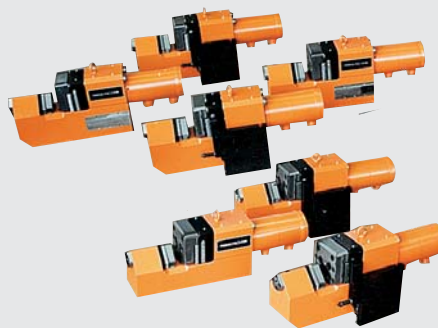

TOX®-Tongs Fixtures in single and multipoint design, specially adapted to your component. They are pneumatic, pneumatic-hydraulic or hydraulic driven.



TOX®-Robot- and Machine tongs with pneumo-hydraulic, electric- or hydraulic drive.

TOX®-FinePress

High-quality benchtop presses – compact and perfect.



TOX®-Production Machine

TOX®-Presses with integrated multipoint die sets. Our know-how, your advantage.

TOX®-PowerKurver

for simultaneous clamping and joining. No need for repeated clamping and fixturing. Optimal accessibility for large panels due to > 90° operating angle. With pneumatic or electric drive.





TOX®-Controls and TOX®-Monitoring

See "TOX®-Controls"
catalog for detailed
information

NETWORK

TOX® softWare
Ethernet
Interbus/ProfiNet/Profibus
RS 232/485
PLC

TOX® process monitoring keeps a constant check on your clinch points.

The specially adapted **process monitoring system** for the **TOX®-Joining technique** helps you to check the **competitive factor of quality**:

- for **each** produced **component**
- for **each** clinch **point** in the component

A **cost effective production monitoring** for short cycle times requires a control system which is integrated into the line - in short, a system like the TOX® process monitoring system.

The TOX® process monitoring system guarantees your quality standards, not only for **mass production**, but also for **small-scale manufacturing**.

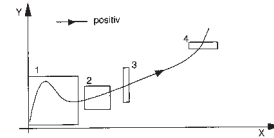

Evaluation Units for Monitoring of Clinch Processes

Resistance to pull and shear loads is dependent on the control dimension "X", provided that the joining parameters and the service life of the tools have been observed.

The evaluation device can be selected according to each requirement. From 1- to 16-channel clinch monitoring all the way to continuous measuring in force-travel-pressing monitoring.

Various evaluation methods allow for different analysis of your processes. Diverse communication interfaces allow for simple and quick data transfer to the data storage.

TOX® process monitoring CEP 400



- Force monitoring of clinching processes
- Trend monitoring
- Process sequencing
- Network capability over Ethernet TCP/IP
- Expandable to userdefined processes
- With and without display

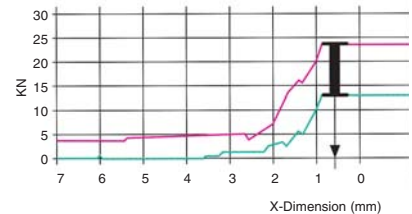

Functional principle:

Force sensors measure the press force at the clinch points. A position indicator monitors the attainment of control dimension "X" (quality dimension). Once the position indicator signals that control dimension "X" has

been reached, the press forces measured by the load cells are compared with the nominal press forces. The TOX® point is satisfactory if the measured press force lies within the preset tolerance range. Thus, it is possible to make an assessment on mate-

rial type, strength and thickness, right tool combination as well as tool failure or missing layer of sheet metal. As alternative it is possible to evaluate the complete Force-Travel characteristic curve (EPW 400 measuring principle).

TOX®-ToolCheck pneumatic testing of clinching dies

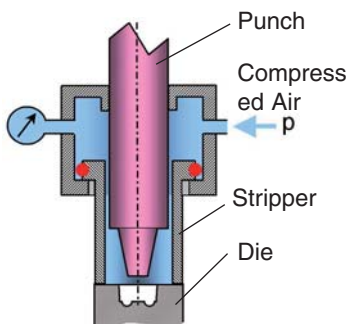

The die monitoring system TOX®-ToolCheck, together with the process monitoring, checks the condition of the TOX® clinching dies. This ensures that the joining process is always performed with an intact die. Any potential defects, like missing or (e.g. by contamination) jammed moving elements of the SKB die, as well as ruptures on either the solid TOX® die

or on the fixed segments of SKB, are identified within < 1 second.

- + Optimum tool life quantity
- + Increase production reliability
- + Maximum tool life usage

For detailed information, see TOX® Data Sheet 80.06.



Controlled Precision Clinching using Electric Servo Drives

The dimension "X" defines the joint quality!

Now it's possible to precisely control the dimension "X", the remaining bottom thickness of the joint after the clinching process, by simultaneously compensating for the deflection of the press unit.

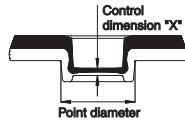

The dimension "X" is determined in the TOX® test labs.

Now:

- + active stabilization of variances
 - technical optimum achieved with an accuracy of $\pm 0,04$ mm
- + Flexibility, precision, minimum setup times
- + the dimension "X" is assured independent of material combination and properties

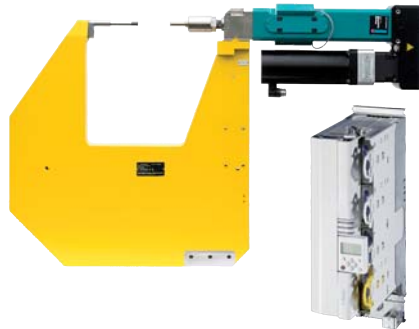

Typical Application:

TOX®-Clinch Robot-Tongs with a compact electromechanical servo drive EPMK and controller including the free TOX®softWare.

TOX®softWare = User friendly

- + Automated learning of the processes and the force limits in the target window, as well as for the envelope.
- + No programming, only parameterizing
- + automatic scaling of the envelope display
- + simple, user friendly user platform

Process monitoring using envelope curves

- + Full monitoring within the set point and target windows, i.e. the force/travel characteristics curve can not fall outside the upper and lower limits
- + Decide for yourself! For curves deviating from the envelope, these options apply:
 - process will continue until target window is reached
 - stop process
- + TOX®softWare Included with delivery: This software, specially developed by TOX® PRESSOTECHNIK, integrates all appropriately equipped TOX® products. Programming, visualization and displaying, networking and archiving, all this can be done using a common platform.

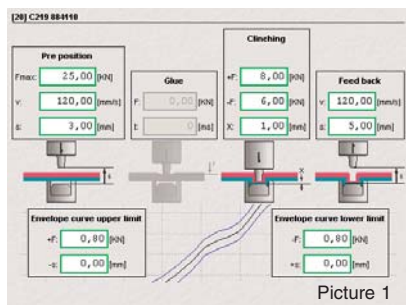

Picture 1

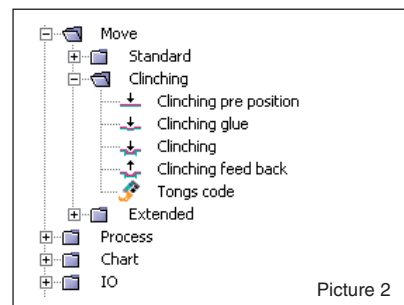

Picture 2

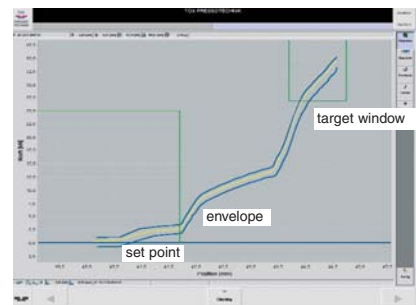

Picture 1: this easy! Input of parameters for the clinch process is done directly on the screen.

Picture 2 shows examples of available operating commands.

TOX®-Joining Equipment for Solid Punch Rivets

With the introduction of the solid punch riveting technology another solely mechanical joining method is added to the portfolio of TOX® sheet metal joining systems. Solid punch riveting has its preferred applications in the field of automotive lightweight constructions, respectively for the joining of hybrid components and assemblies of alternative materials. TOX® complete solutions include the knowhow, the competence and the

equipment for all solid punch riveting requirements: the technology, the tooling, presses and riveting devices, single or multiple rivet supply lines, controls. The rivet placing can be accomplished by c-bow or column presses, hand held or robot tongs as well as by custom made devices and machines. More information on these TOX® systems is provided in data sheet 100.05.



Typical shape of a solid punch rivet



Our Worldwide Sales and Service Network

Product Range

TOX®-Powerpackage



TOX®-PowerKurver



TOX®-ElectricDrive



TOX®-FinePress



TOX®-Presses



TOX®-Controls
TOX®-Monitoring



TOX®-Joining-Systems



TOX®-Tongs



TOX®-Punching
TOX®-Coining



TOX®-Press-Fitting



TOX®-Production Systems



TOX® PRESSOTECHNIK GMBH & CO. KG
 Riedstraße 4
 D-88250 Weingarten
 Tel. +49 (0) 7 51 / 50 07-0
 Fax +49 (0) 7 51 / 5 23 91
 E-Mail: info@tox-de.com
 www.tox-de.com

TOX® PRESSOTECHNIK L.L.C.
 4250 Weaver Parkway
 Warrenville, IL 60555
 Tel. (6 30) 3 93-03 00
 Fax (6 30) 3 93-68 00
 E-Mail: info@tox-us.com
 www.tox-us.com