

# Modular C-frame programme

## Series CEJ

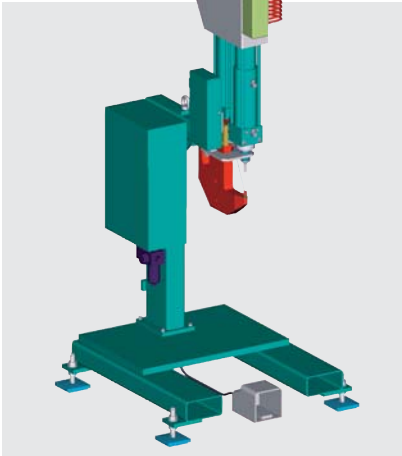

Picture shows:  
Flexible modular system provides a universal upright press.

### Example: bracket CEJ

consisting of:

- CEJ ..... bracket
- Drive..... TOX®-Powerpackage RZK/RZH/RZS/EPMR
- CER..... support for holding the CEJ
- CLX ..... safety device (see page 16)

### Additional Accessories

- STE ..... safety control
- CZP ..... holding fixture
- CSR..... punch stripper
- ZKF ..... coupling flange
- ZL ..... target feature with light spot (see page 16)

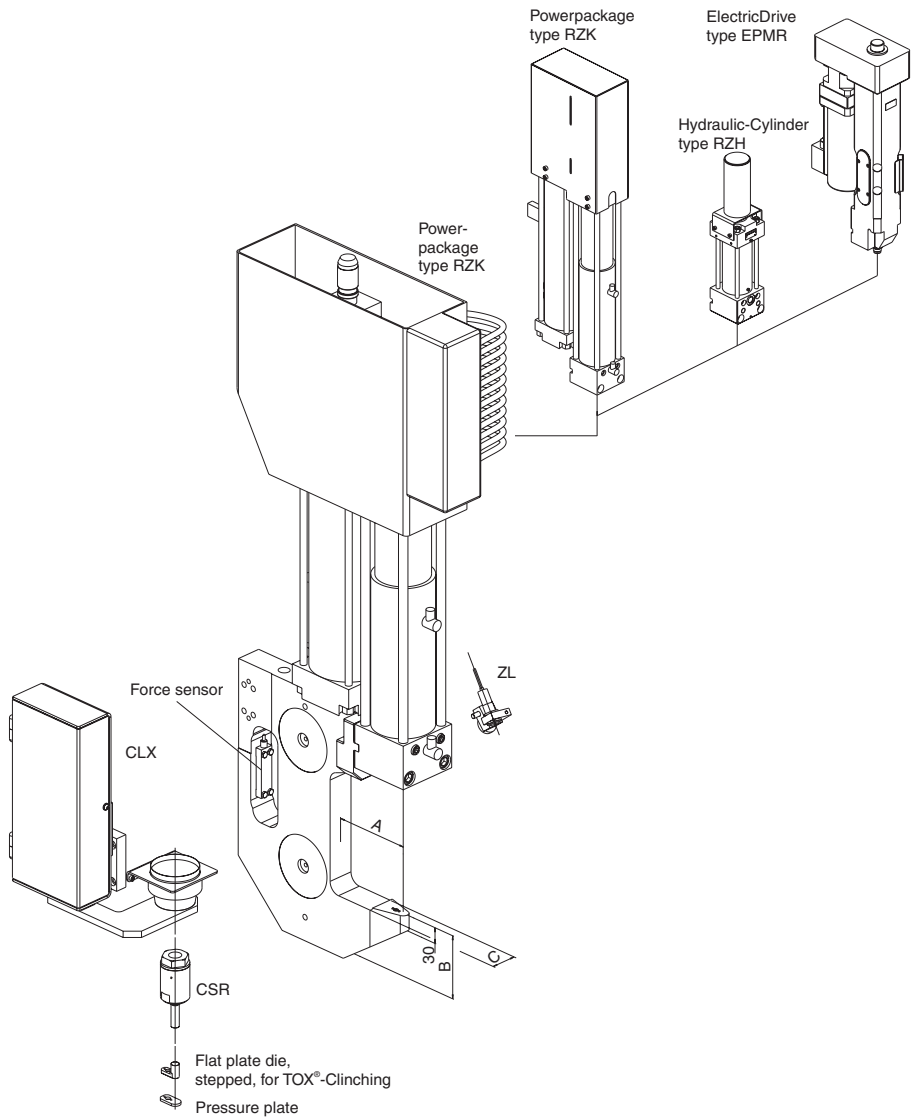

### Press CEJ:

The C-frames can be designed according to the requirements. The press force, tool geometry or tool adapters can be changed as required.

### Support CER:

Of solid welded construction with large open space so that the C-frame CEJ can be mounted in such a way that an optimal handling of the component by the operator is possible.

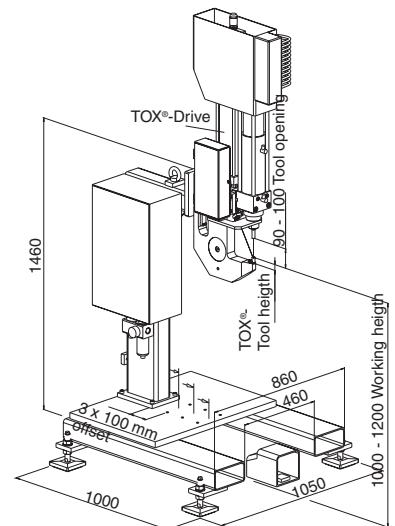

### CEJ 50

order number	max. press force kN (t)	stroke	A	B	C
CEJ 50.100	50 (5)	100	100	75	40
CEJ 50.150	50 (5)	100	150	115	40
CEJ 50.200	50 (5)	100	200	145	40

All dimensions in mm.

### CEJ 80

order number	max. press force kN (t)	stroke	A	B	C
CEJ 80.100	80 (8)	100	100	85	50
CEJ 80.150	80 (8)	100	150	120	50
CEJ 80.200	80 (8)	100	200	165	50

All dimensions in mm.