

C-frame bed presses

Series MC



Picture shows:
Stable cast iron construction
with adjustable tool area.

Example: press MC

consisting of:

- MC..... TOX®-Press
- Drive TOX®-Powerpackage
S/K/KT/EPM
- ZWK tool holding fixture
- STE safety control (see page 17)
- UUM universal base frame (see page 15)

Additional Accessories

- V anti-torsion lock
- ZDO pressure switch

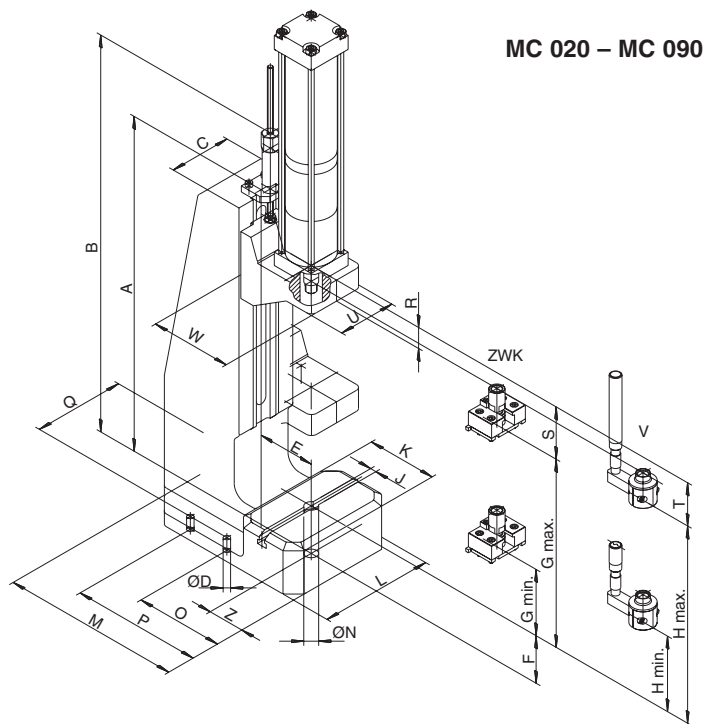

MC 020 – MC 090

MC 150

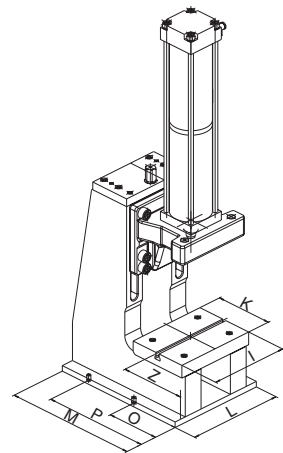

TOX®-Presses MC

order number	max. capacity kN (t)	TOX®-Powerpackage	A	B	C	ØD	E	F	G _{min.}	G _{max.}	H _{min.}	H _{max.}	T-slot DIN J _{H11}	K	I	L	M	ØN	O	P	Q	R	S	T (V height)	U	W	Z
MC 020	20 (2)	S / K 2	550	685	102	2xØ10x21	86	78	109	309	124	324	10	115	-	187	295	20	145	-	150	34,5	86	71	95	134	60
MC 048	48 (4.8)	S / K 4	545	590	160	2xØ14x90	130	105	131,5	291,5	131,5	291,5	14	190	-	250	385	-	235	-	200	43,5	88,5	88,5	120	190	95
MC 090	90 (9)	S / K 8	660	705	210	2xØ14x145	150	160	209	305	199	295	14	220	-	310	500	-	290	-	260	57	105	115	205	220	105
MC 090T	90 (9)	S / K 8	855	900	221	2xØ14x193	150	210	170	420	180	430	14	220	-	318	550	-	290	-	260	57	125	115	205	220	105
MC 150	150 (15)	S / K 15	703	751	270	4xØ13x20	150	211	196	296	181	281	14	216	296	360	500	-	200	400	325	72	126	141	280	253	110

All dimensions in mm.